

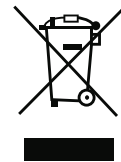

LED TROFFER

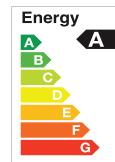

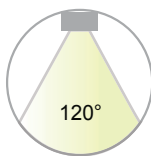

Features & Benefits

1. 115lm/w for options.
2. Die formed of 0.5mm cold-rolled steel body.
3. 0-10v dimming, universal voltage: 100-277v.
4. Wide application for: school, hospital, super market, office and warehouse.
5. Fully recessed luminaire fits standard T-Grid ceilings.
6. High-diffusion light-milky PS diffuser .
7. 5-year warranty.

Product Dimension

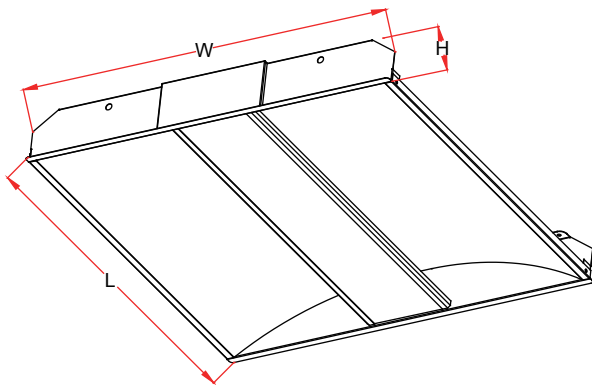

Model	L×W×H
E1903-22	603x603x80 (mm)/23.74"x23.74"x3.15"
E1903-14	1213x303x80(mm)/47.76"x11.93"x3.15"
E1903-24	1213x603x80(mm)/47.76"x23.74"x3.15"

Specification

Part No.	Power	Input Voltage	Luminous Flux	Luminous Efficacy	CCT	Viewing Angle	Ra	PF	Warranty
E1903-22-30W	30W	AC100-277V	3450lm	115lm/W	3500K 4000K 5000K	120°	>80	>0.9	5Years
E1903-22-40W	40W		4600lm						
E1903-14-30W	30W		3450lm						
E1903-14-40W	40W		4600lm						
E1903-24-40W	40W		4600lm						
E1903-24-50W	50W		5750lm						



Testing Report

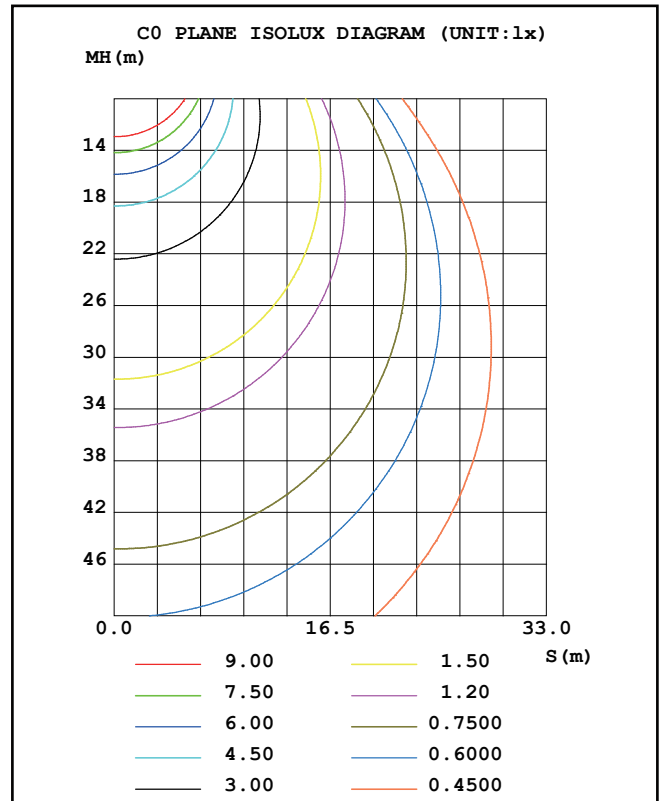
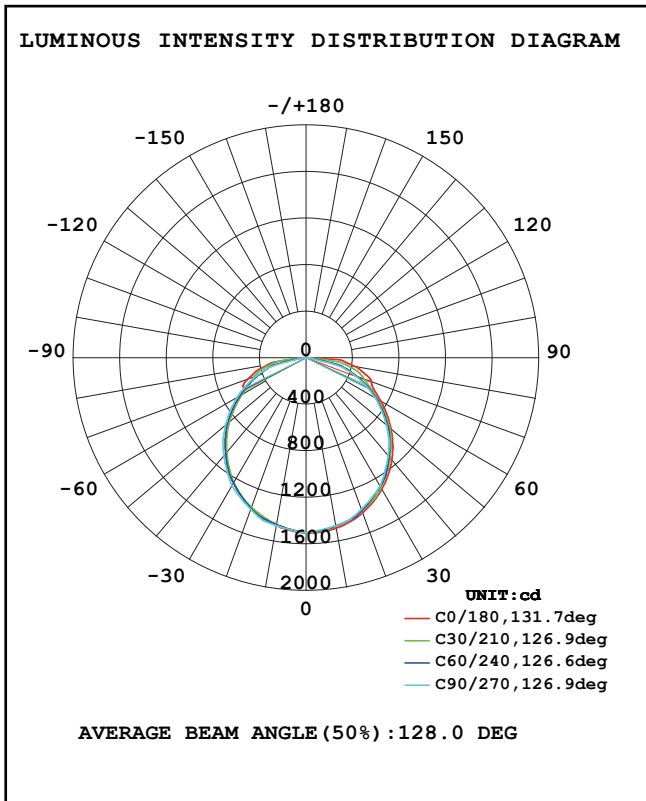

Applications





CCT AND WATT CHANGING

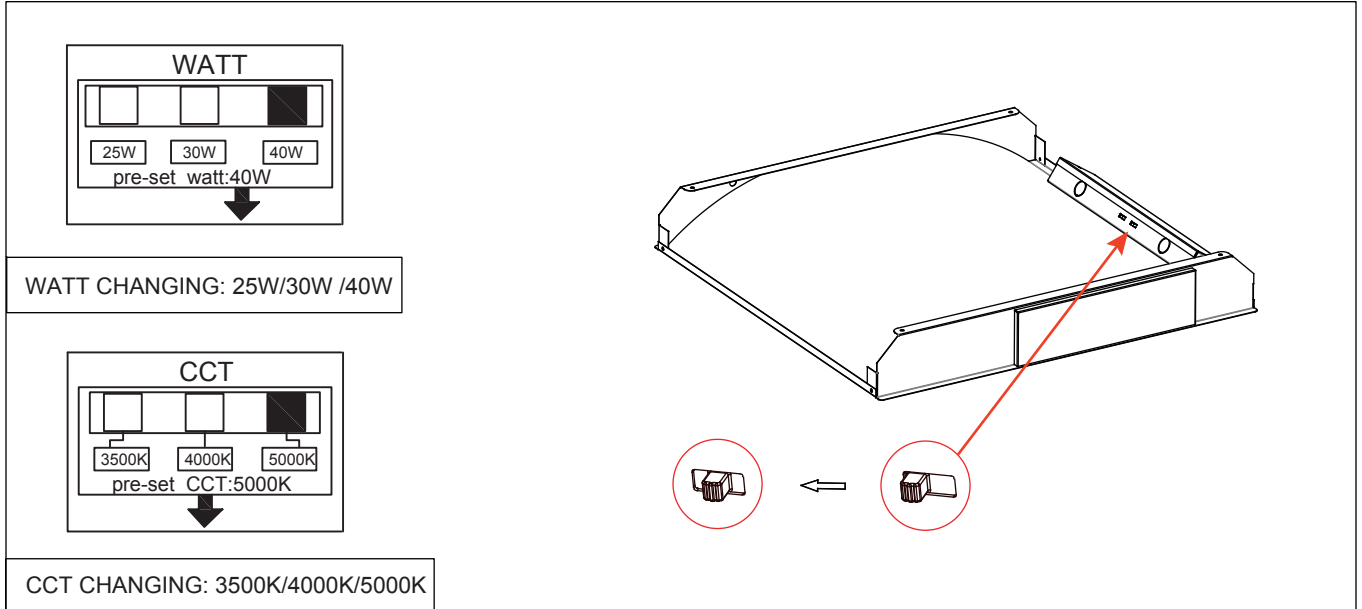

Installation manual

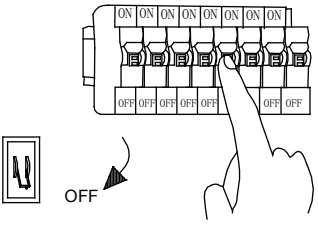
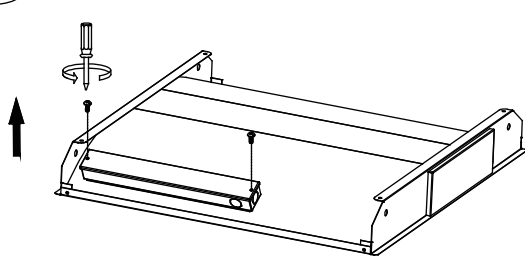
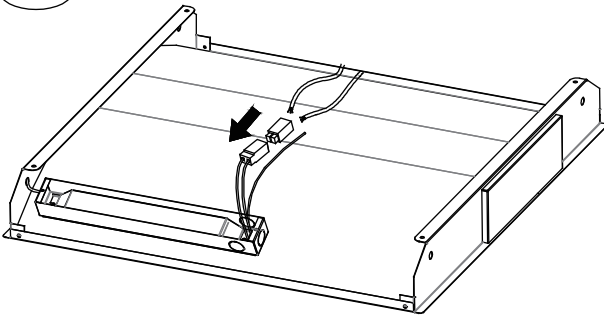
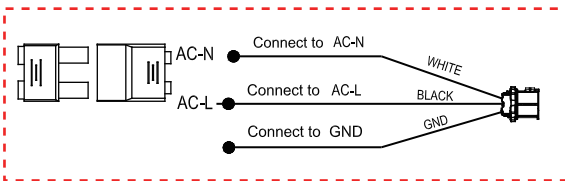
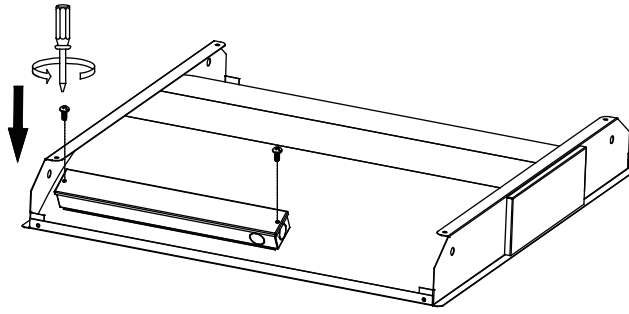
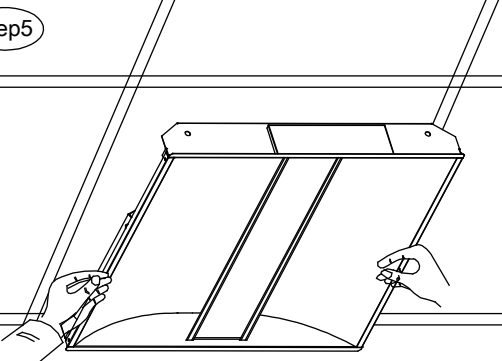
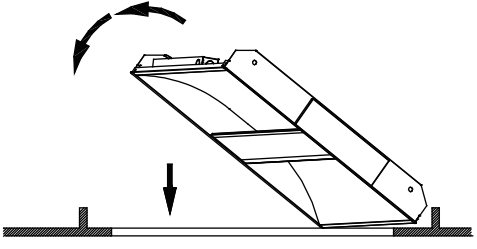
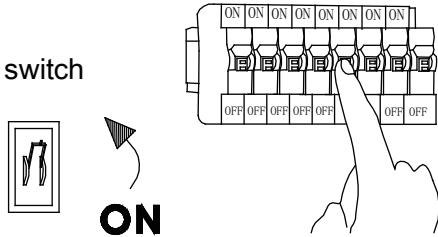
<p>Step1</p>  <p>Turn off the switch</p>	<p>Step2</p> 
<p>Step3</p>  <p>Wiring Diagram</p>  <p>AC-N Connect to AC-N WHITE AC-L Connect to AC-L BLACK GND Connect to GND</p>	<p>Step4</p> 
<p>Step5</p> 	<p>Step6</p> 
<p>Step7</p> <p>Turn on the switch</p>  <p>ON</p>	



Important

Read this instruction carefully before installation. Keep it for further reference.
Make electrical and grounded connections in accordance with the national electrical code and any applicable code. Always turn off the power supply before installation.
This product must be installed in accordance with the applicable installation code by a qualified electrician who is familiar with the construction and operation of the product and the hazards involved.

WARNING:

- ⚠ Risk of fire or electric shock. Fixture installation requires knowledge of luminaires electrical systems. If not qualified, DO NOT attempt installation. Contact a qualified electrician.
- ⚠ Risk of fire or electric shock. Suitable for wet locations. Always turn off the power supply before installation.
- ⚠ Risk of fire or electric shock. Suitable for non-insulated surface and frame. DO NOT cover fixture with insulation liner or similar material.
- ⚠ DO NOT install fixture on unstable, loose or easily breakable surface.
- ⚠ DO NOT exert force on the surface of the fixture.

Packing /weight

Model No.	Outer box (L*W*H)	Qty/Ctn (pcs)	N.W/pcs (lbs/Kg)	G.W/Ctn (lbs/Kg)
E1903-22	25.2"x3.94"x25.39" 640*100*645mm	1	7.7 / 3.5	9.02/ 4.1
E1903-14	13.39"x3.94"x49.21" 340*100*1250mm	1	8.14 / 3.7	9.68/ 4.4
E1903-24	25.2"x3.94"x49.21" 640*100*1250mm	1	14.52 / 6.6	16.95/7.7

Note

- 1.The installation and maintenance must be completed by electricians or professionals.
- 2.Please cut off the power before installation and maintenance.
- 3.The thermally insulating material is not allowed to cover the fixture.
- 4.Please keep away from the corrosive substance, and keep the fixture dry and clean.
- 5.Working temperature: -4°F~113°F, storage temperature: -22°F~140°F.